

AUTOSAR

M. van der Cruijssen



HUMIQ

Advanced Software

2 juni 2010

www.humiq.nl

1

AUTomotive Open System ARchitecture

- AUTOSAR is an open and standardized automotive software architecture

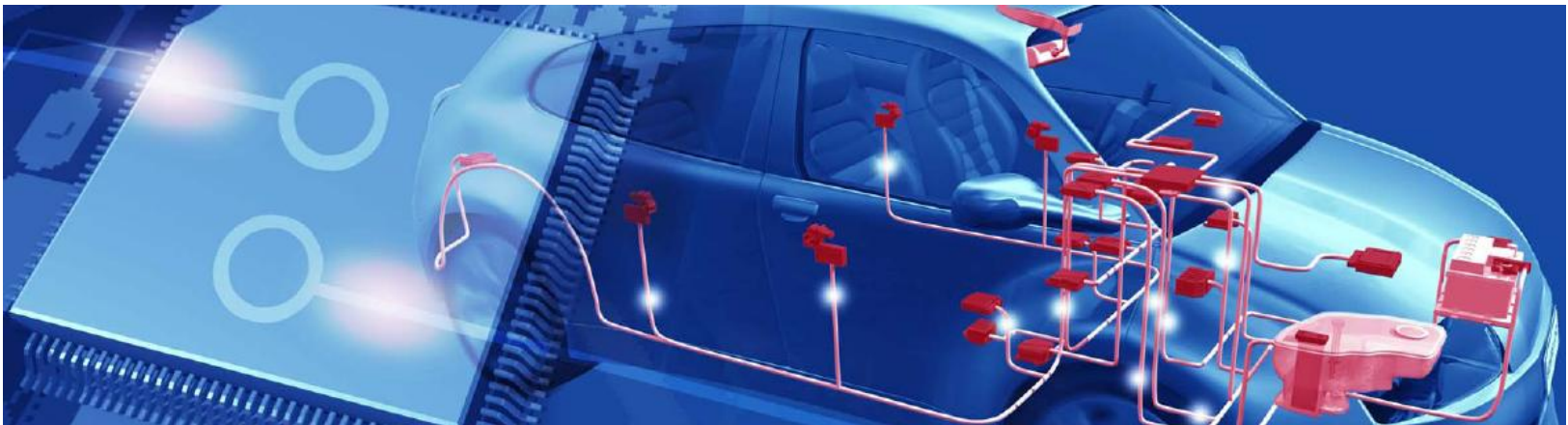

<http://www.autosar.org>

- Increasing share of electronics in vehicle value
 - Electronics share (in value): 2004: 20% > 2015: 40%
(McKinsey, Automotive Electronics -Managing innovations on the road)
 - Software share (in value): 2000: 4,5% > 2010: 13%
(MercerConsulting, Automobile technologie 2010)

Challenges in Automotive E/E Development

- Extend product offering and increase product differentiation
 - Stable or decreasing development costs
- Strengthen brand image in the market
 - Propose specific features and functions across the product range
- Ensure long term competitiveness, and presence in emerging markets, through cost reduction
- Increase quality and reduce “non quality” costs

■ Exchangeability and Reuse of Software Components

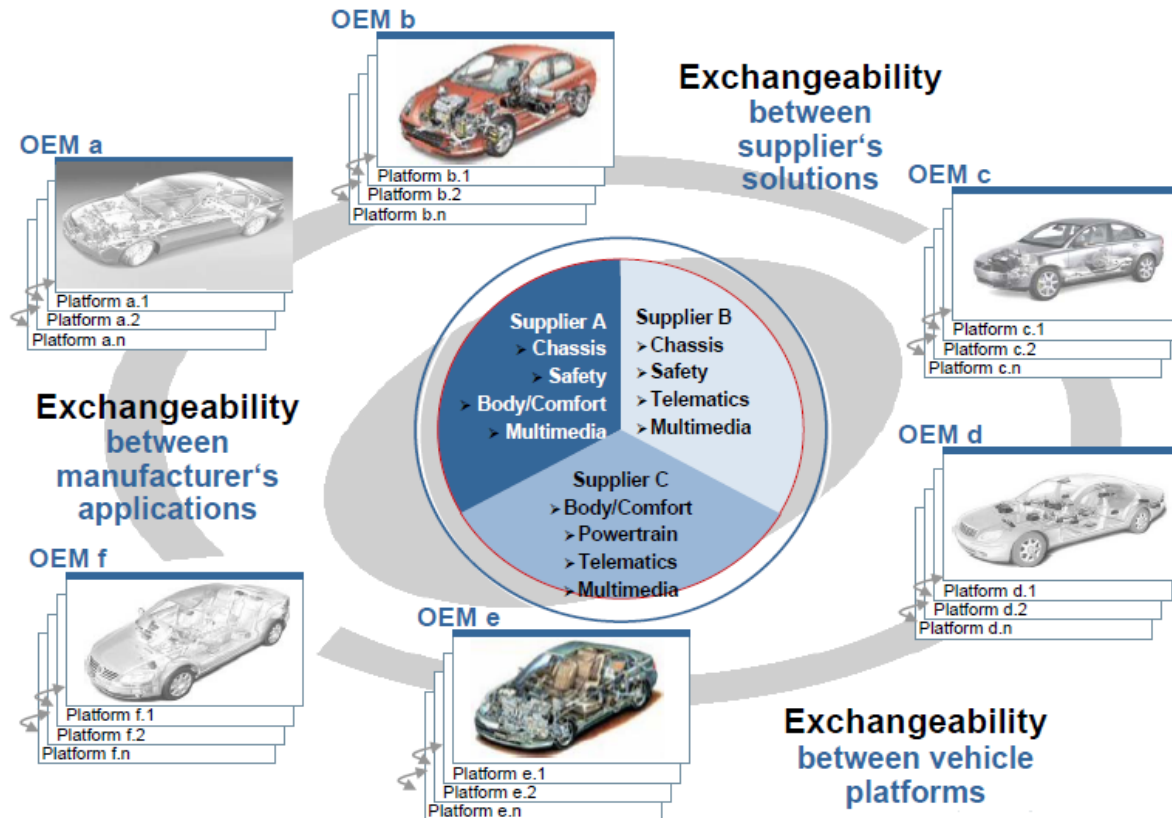

- AUTOSAR merges existing standards

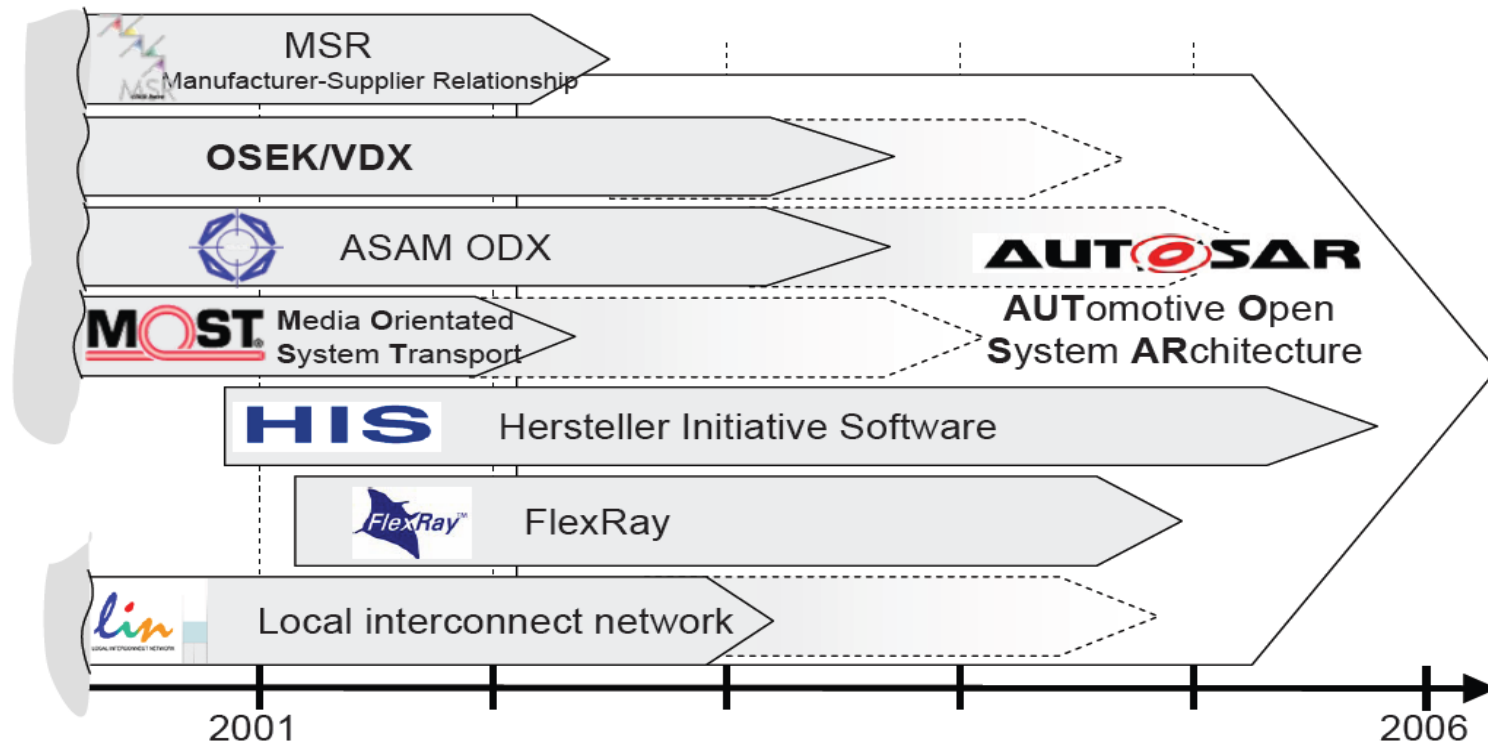

AUTOSAR provides three main areas of results:

- Basic Software:

- Complete basic software stack for hardware independent SW applications

- Methods of Software Integration:

- Exchange formats (templates) to enable a seamless configuration process

- Functional API:

- Specification of functional interfaces as standard for application software modules

Technical Concept

VFB view

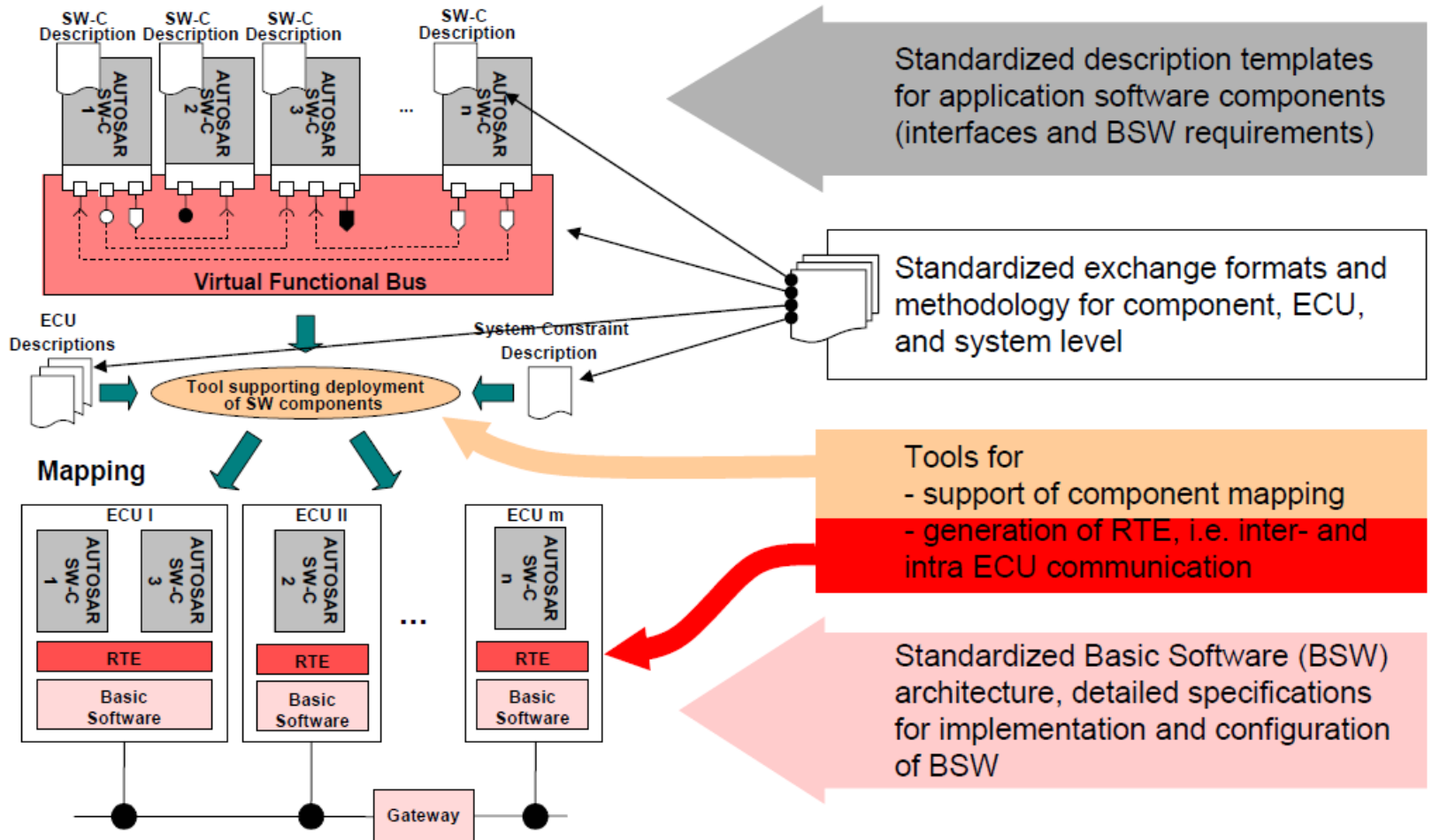

Technical Concept

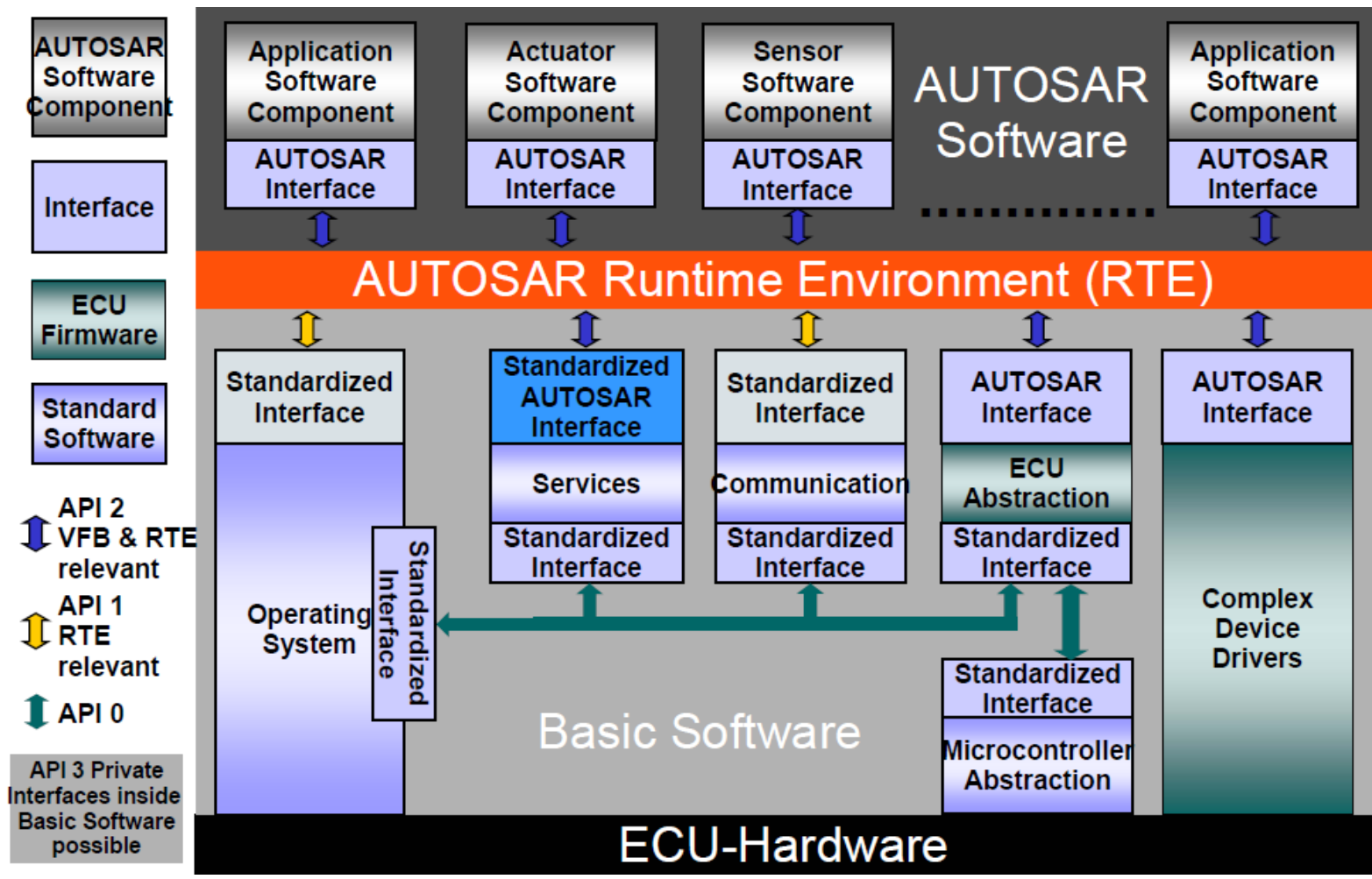

Technical Concept

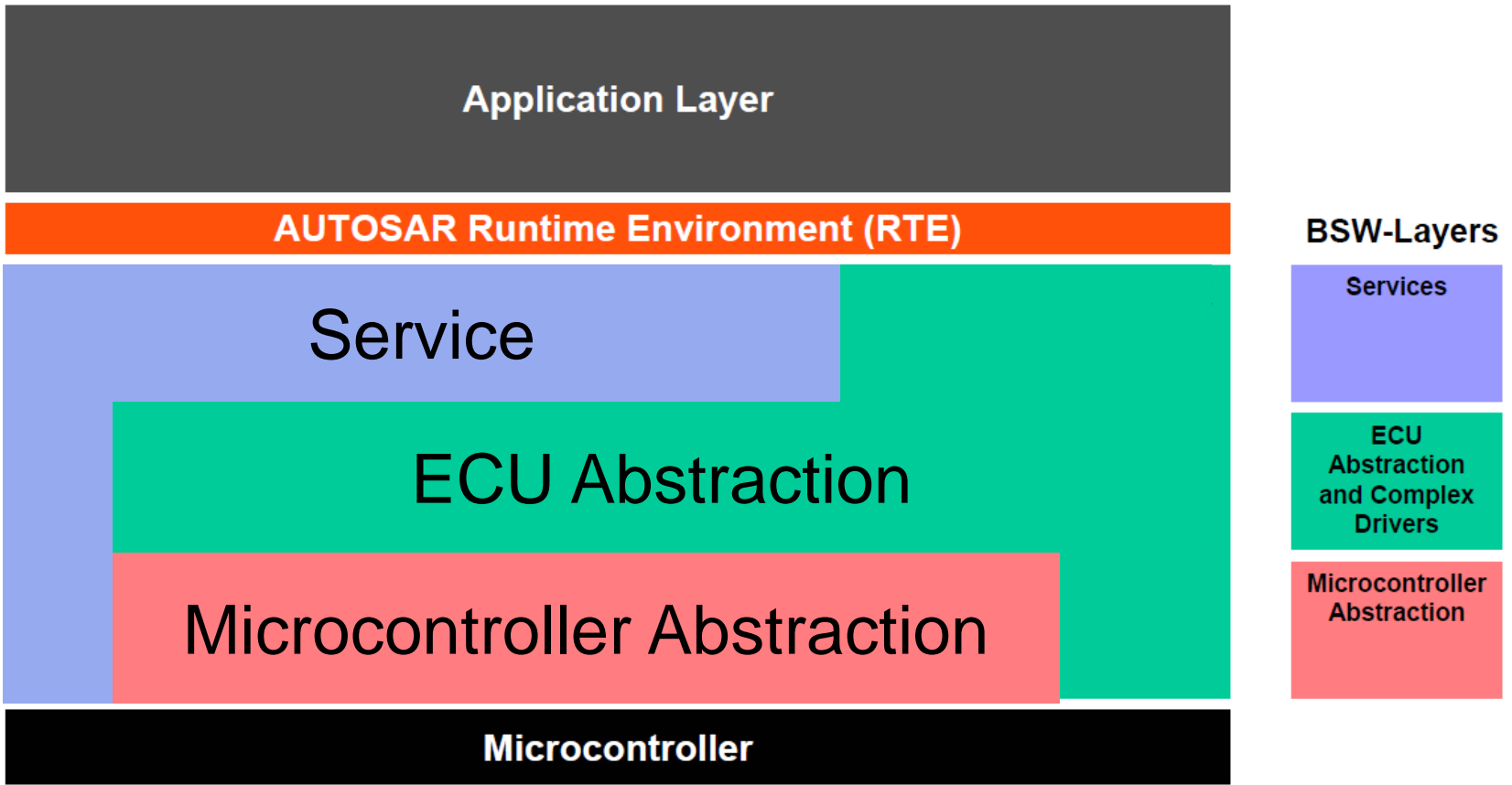

Technical Concept

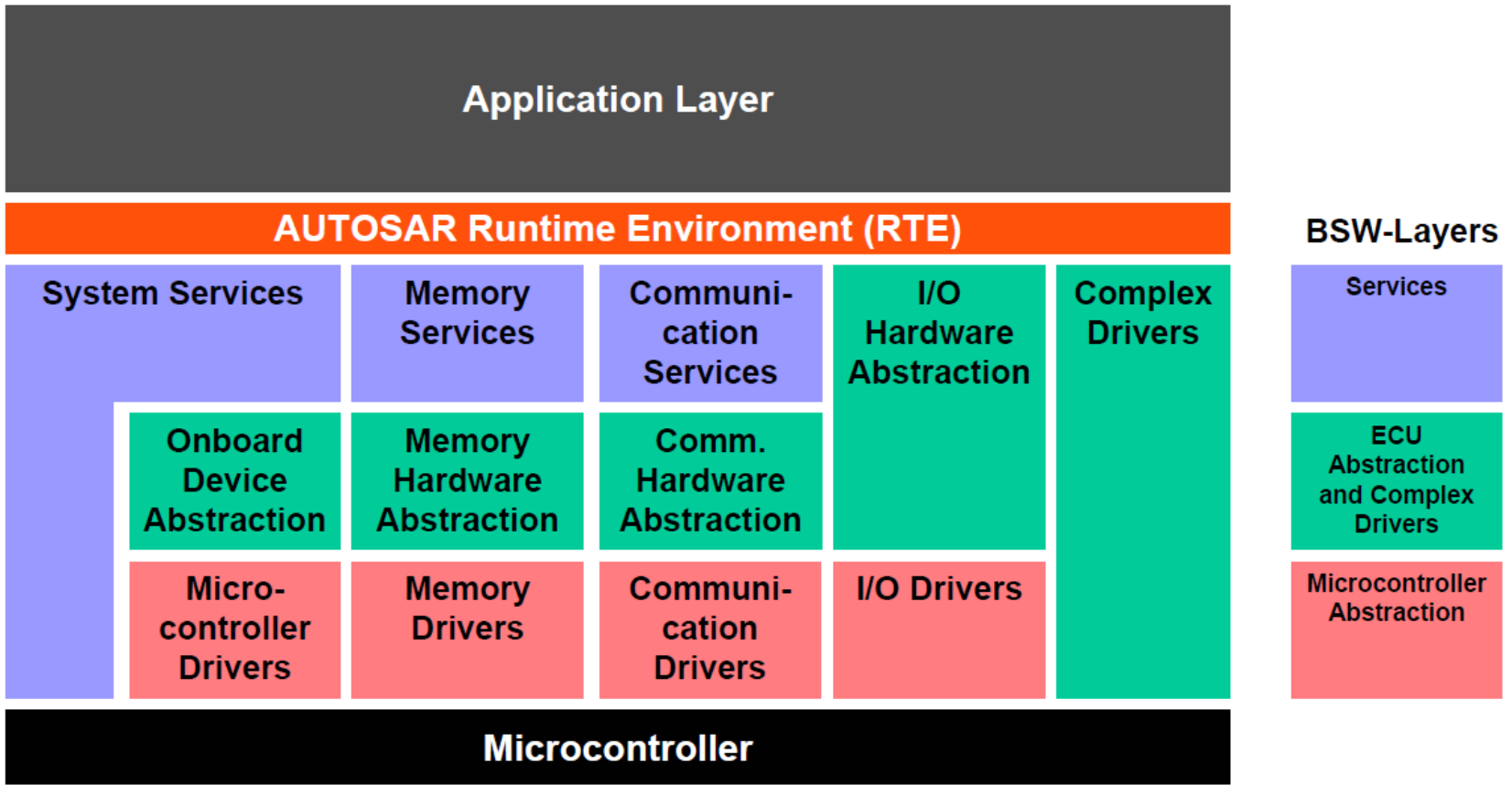

Technical Concept

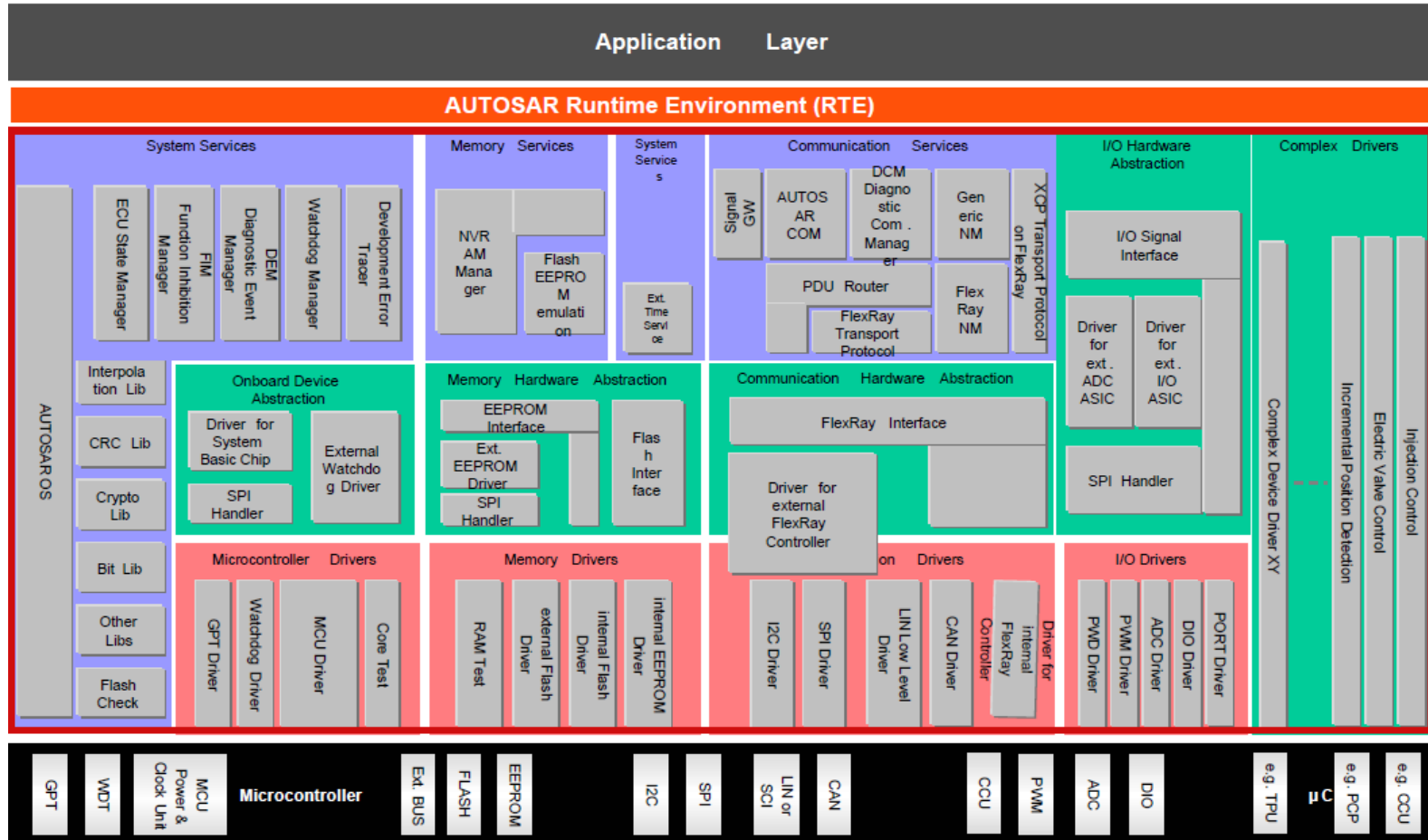

Technical Example

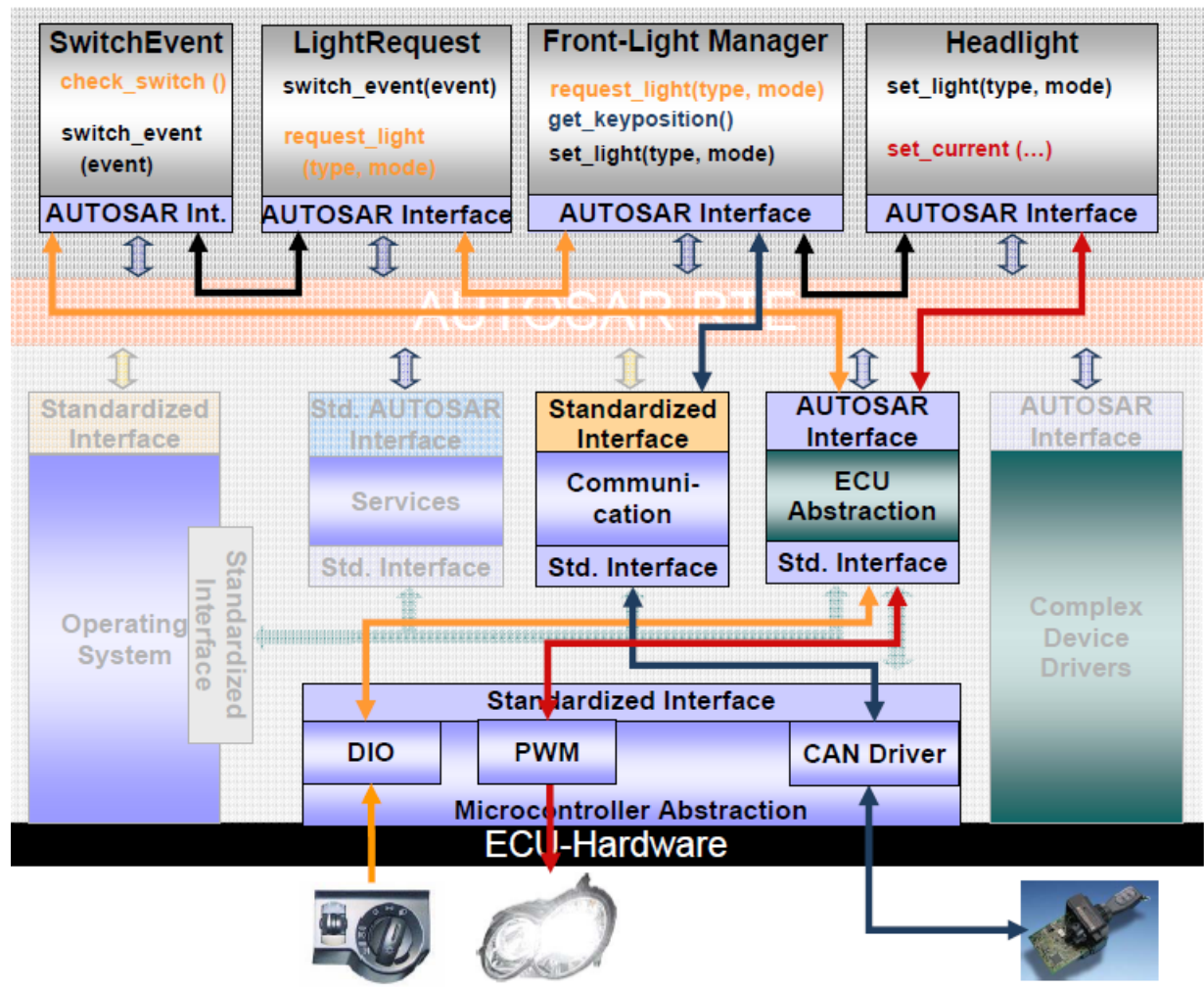

Technical Example

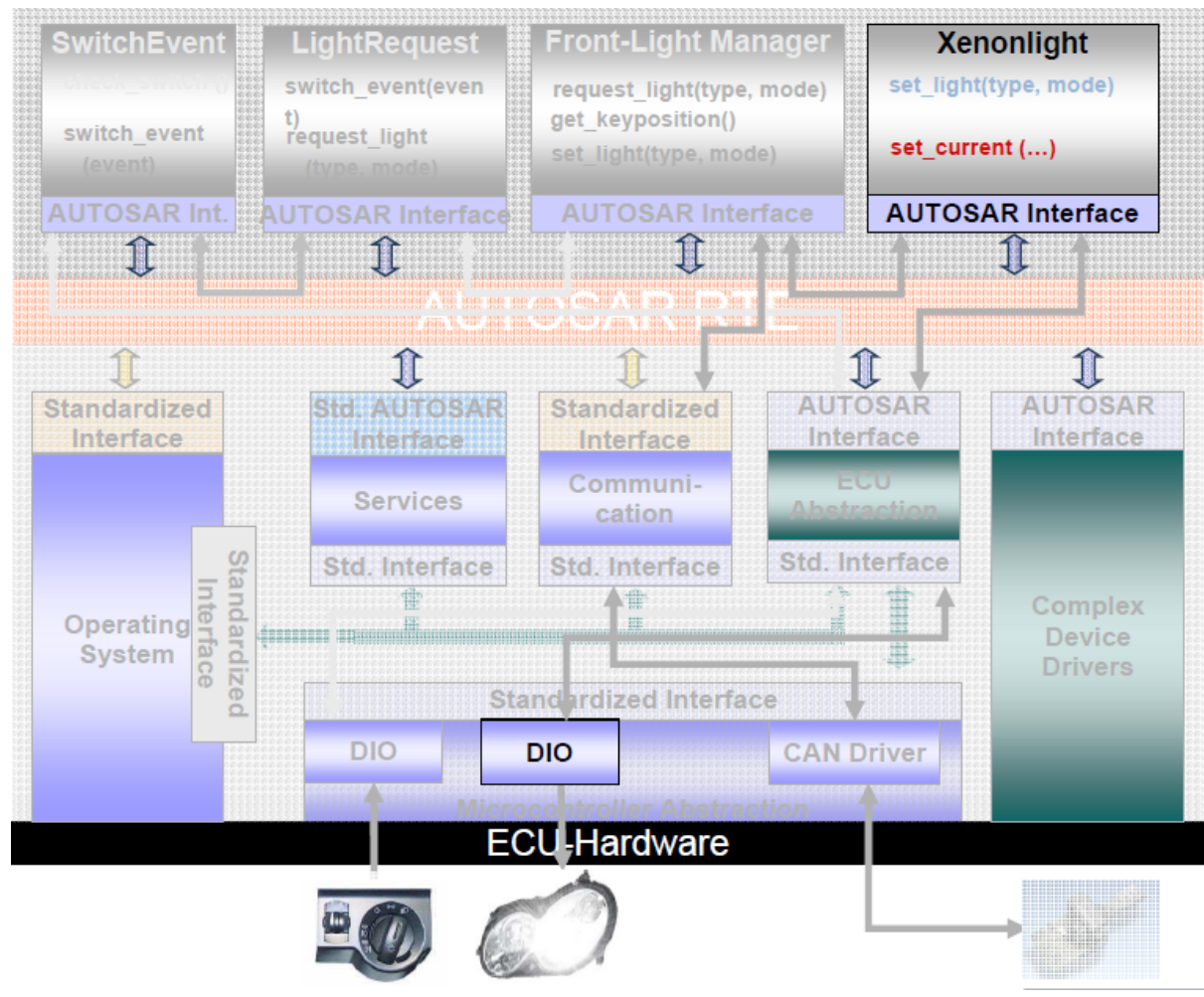

Technical Example

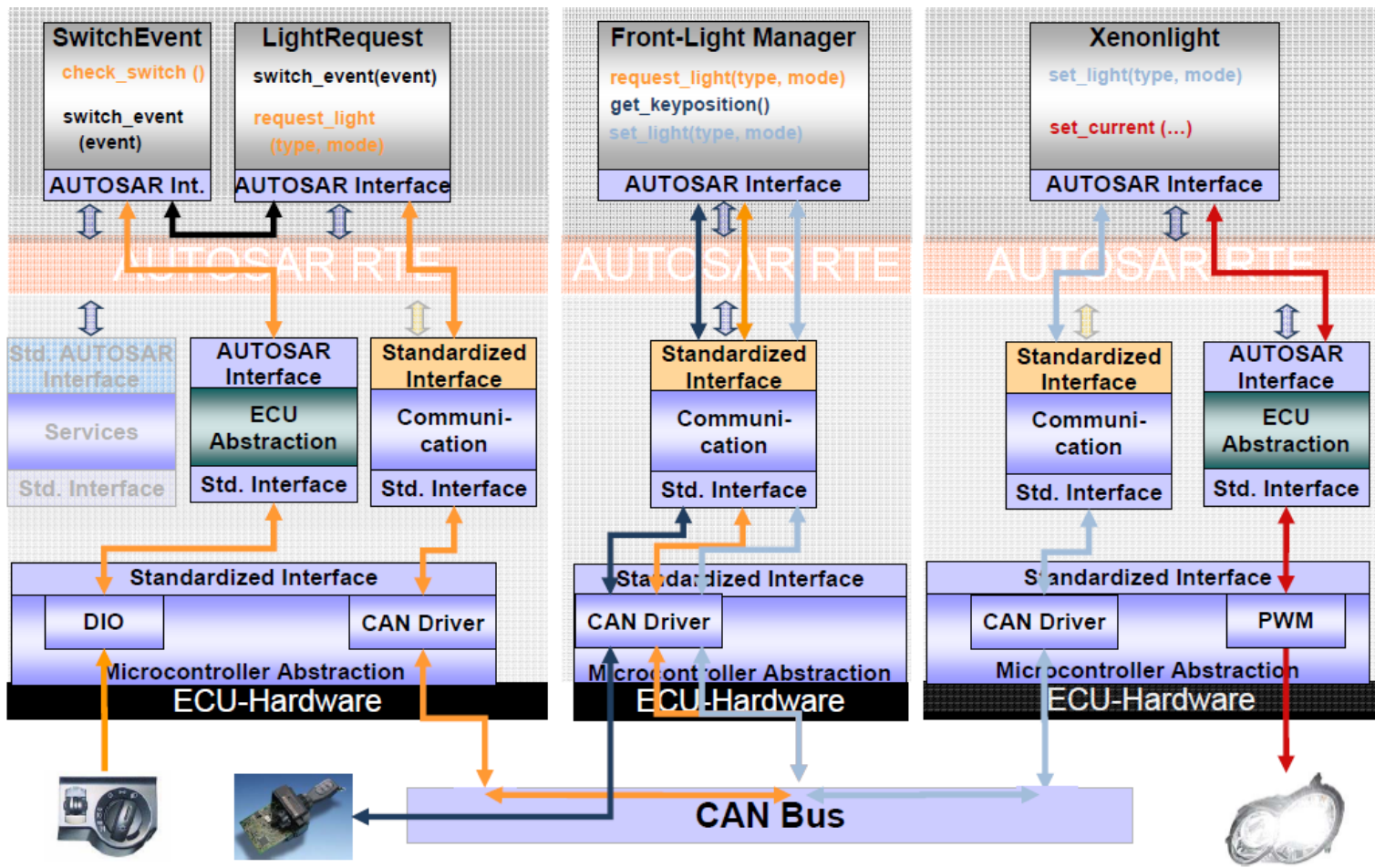

Benefits and Changes

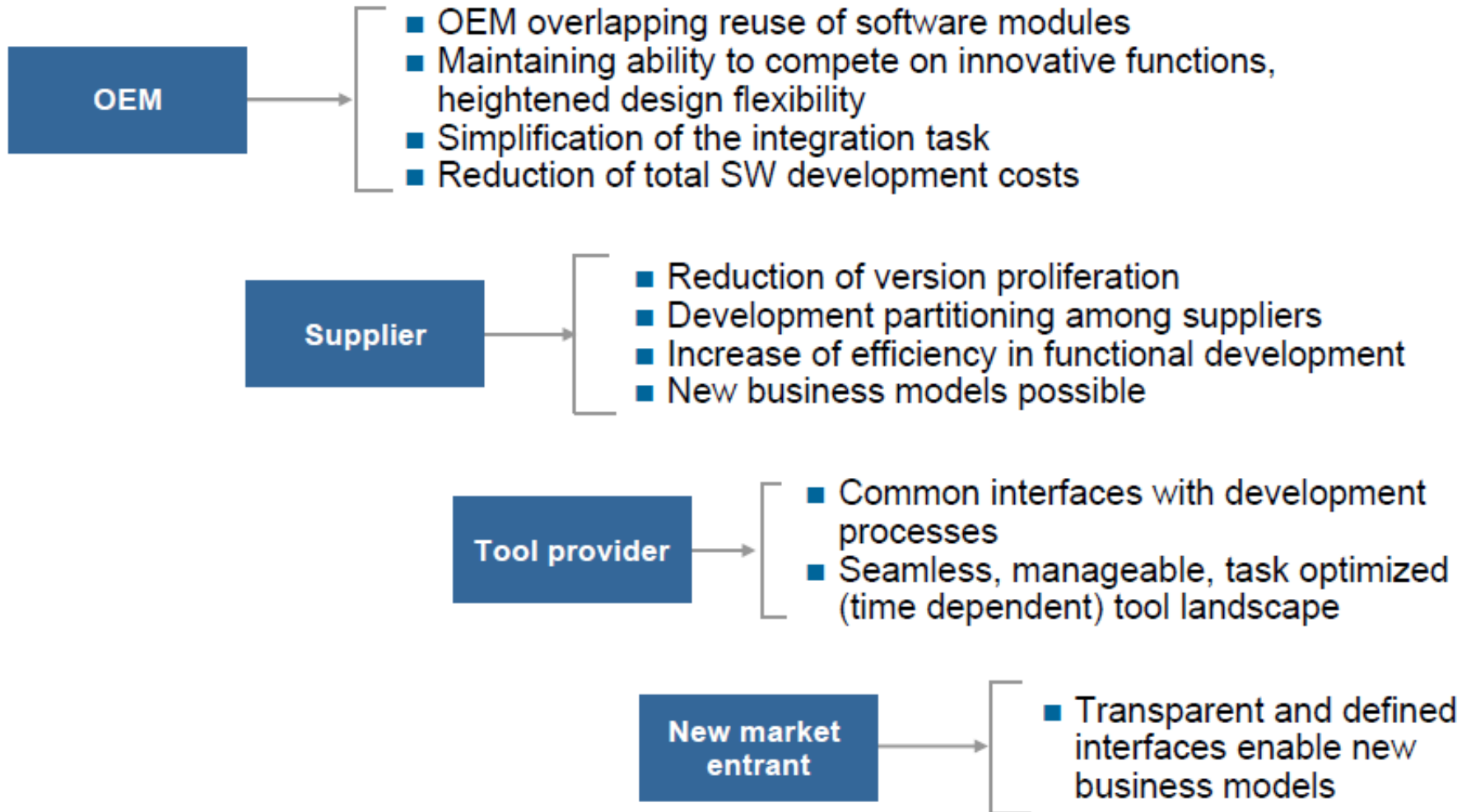

Benefits and Changes

Automotive Software Development will change.

Conventional, by now

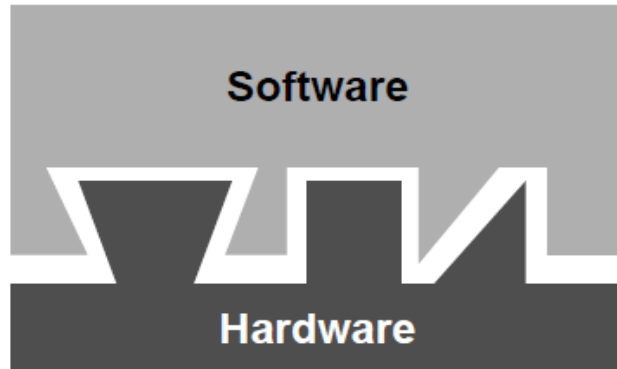

AUTOSAR

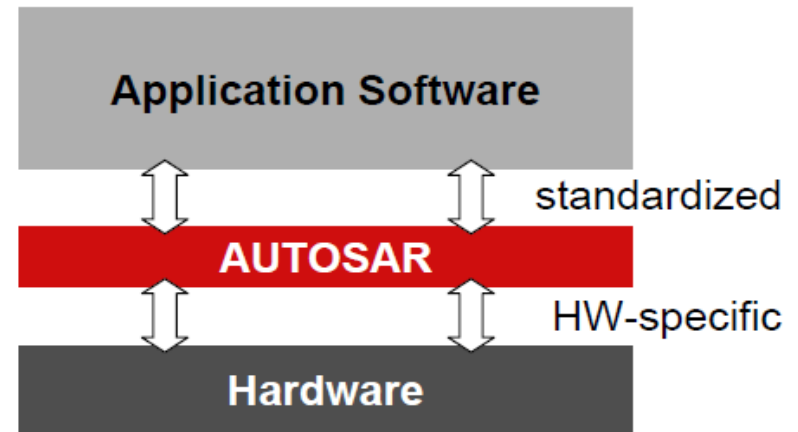

- Hardware-and software will be independent
- Development processes will be simplified.
- Reuse of software at OEM and suppliers.

Software becomes a Product

Questions

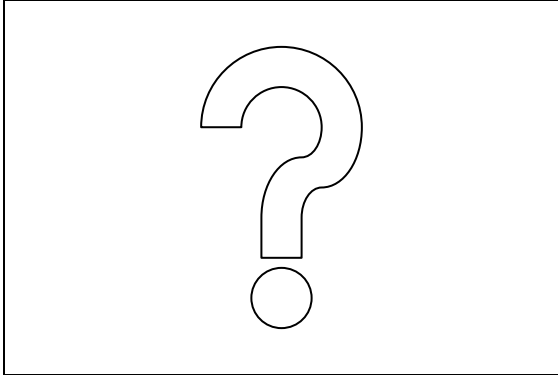



Martijn.van.der.Cruisen@HUMIQ.nl

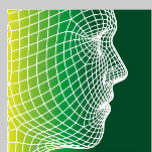

HUMIQ

Advanced Software

2 juni 2010

www.humiq.nl

19